

THWAITES 3 TONNE POWER SWIVEL DUMPER

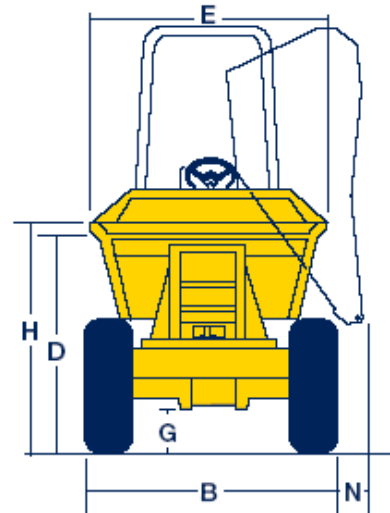
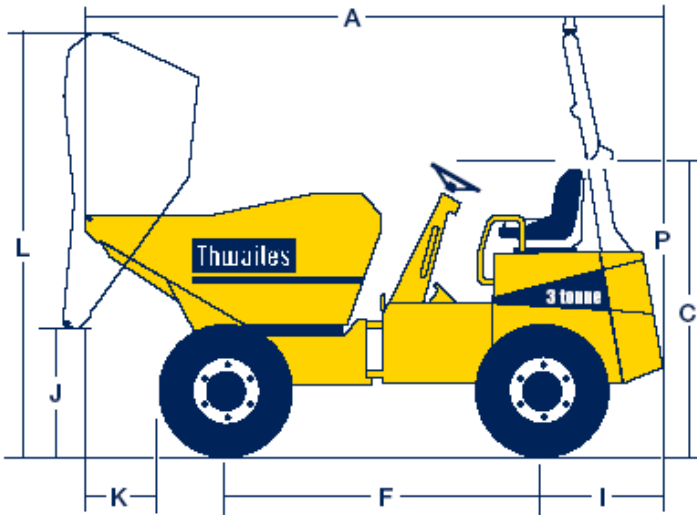

DIMENSIONS	
mm	
A	4010
B	1840
C	2013
D	1520
E	1770
F	1930
G	280
H	1600
I	1130
J	1110
K	530
L	3290
M	2120
N	190
P	3140

CAPACITIES	
Max. safe load	3000 kg
Heaped	1870 litres
Struck	1350 litres
Water	1100 litres
Unladen Weight	2260 kg
SPEEDS	
1	2.4 mph
2	5.6 mph
3	10.5 mph
Reverse	2.75 mph
TYRE PRESSURES	
FRONT	3.4 Bar 49 PSI
REAR	2.0 Bar 29 PSI
NOISE LEVELS	
Operators ear	84 LpA
Airborne sound power	102 LwA

KEY FEATURES

- ◆ Thwaites Kinglink chassis provides superior stability and traction for rough terrain.
- ◆ Hydraulic power steering.
- ◆ Hydraulically operated skip with 6mm steel base plate and reinforced sides to minimise skip damage.
- ◆ Front tip and power swivel with rotation through 180°.
- ◆ Automatic safety lock holds skip in the central position when travelling.
- ◆ 4 X 4 drive.
- ◆ Adjustable suspension seat, accessible from both sides.
- ◆ Super bright warning lights for all critical functions.
- ◆ Audible warning device at keystart "on" position.



CALL **VHS** PLANT HIRE on 0121 360 4161

